

# Product Reference Guide

## Model 200 & Model 250

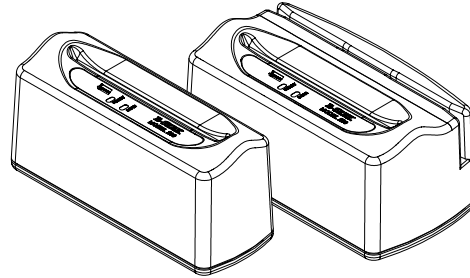

**E-SEEK Inc.**

**[www.e-seekinc.com](http://www.e-seekinc.com)**



## **Product Reference Guide Model 200 & Model 250**

2002 E-Seek Incorporated, All Rights Reserved.

E-Seek reserves the right to make changes to any product to improve reliability, function, or design.

E-Seek does not assume any product liability arising out of, or in connection with, the application or use of the product, circuit, or application described herein.

No license is granted, either expressly or by implication, estoppel, or otherwise under any patent right or patent, covering or relating to any combination, system, apparatus, machine, material method, or process in which E-Seek products might be used. An implied license only exists for equipment, circuits, and subsystems contained in E-Seek products.

E-Seek and E-Seek logo are registered trademarks of E-Seek Incorporated. Other product names mentioned in this manual may be trademarks or registered trademarks of their respective companies and are hereby acknowledged.

E-Seek Incorporated  
4373 Viewridge Avenue  
San Diego, CA 92123  
<http://www.e-seekinc.com>

Patent Pending

## Product Reference Guide

### Parts of the Model 200 2D Bar Code Reader

This page contains an annotated view of the Model 200. This illustration will have lines/arrows to key components of the Model 200. These components include:

1. Cable Interface Connector
2. Power Supply Connector
3. Power On/Red LED
4. Good Read/Green LED
5. Product ID Label
6. Card Insertion Guide

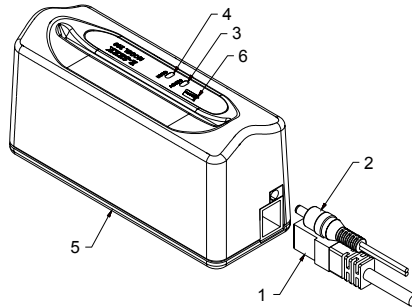

Fig.1

## Parts of the Model 250 2D Bar Code and Magnetic Stripe Reader

This page will provide an illustrated breakdown of the Model 250 just like the previous page with the addition of the Magnetic Stripe Reader.

1. Cable Interface Connector
2. Power Supply Connector
3. Power On/Red LED
4. Good Read/Green LED
5. Product ID Label
6. Card Insertion Guide
7. Magnetic Stripe

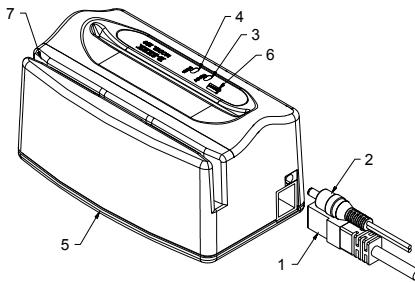

Fig.2

## **Model 200 and Model 250 Product Descriptions**

- The Model 200 is a 2D Bar Code Scanner designed for reading and decoding 2D Bar Code on ID Cards and Driver's Licenses. The Model 200 presents decoded Bar Code information through a 10 pin RS 232 interface utilizing an RJ 45 connector.
  
- Multiple cable options are available to interface to various systems and plug requirements.
  
- The Model 250 provides the same capability as the Model 200 for 2D Bar Code and adds the additional capability of a three track Magnetic Stripe Reader incorporated into one integrated housing.

## Cable Options

1. FIP 11 Interface - DB9 Cable (RD112-022-9A) Connector, Designed for Interface to Hypercom star Terminal FIP 11 Adapter. *This cable also provides for universal RS 232 interface capability through the use of a standard DB9 serial interface connector.*
2. Hypercom Interface - MD9 Cable (RM112-041-9A) Connector, Designed to Interface to Hypercom series 5500 & 5700 Terminals.
3. Verifone Interface - RJ45 Cable (RR498-498-9A) Connector, Designed for any Verifone credit processing terminal.
4. Custom - Other custom interface cables are available on a quotation basis.

## Installing the Interface Cable

Simply connect the RJ 45 male connector on the interface cable to RJ 45 female connector built into the Models 200 and 250 as per the illustration below.

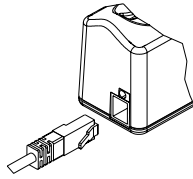

## Installing the Power Supply

Simply connect the Power Supply Module to a convenient AC outlet and the cable to the Model 200/250 as shown below. No power connection is required for Verifone terminals.

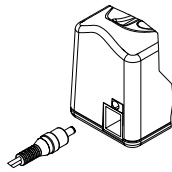

### Scanning a 2D Bar Code with the Model 200/250

Simply insert and remove the card to be read in a smooth and continuous motion. The reader will emit a double beep tone and the green LED will flash on a good read. Orient the bar Code to be read in accordance with the illustration below.

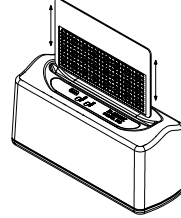

### Reading a Magnetic Stripe with the Model 250

Orient the card to be read as illustrated below, and simply swipe the card through the reader in one smooth and continuous motion in either direction.

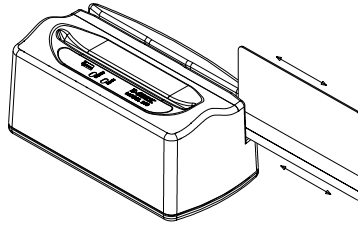

## What does the Beep Mean?

1. When power is applied to the unit, it is automatically powered on, runs a self-diagnostic test and issues a beep tone to signify that it is operational.
2. When the unit is programmed (see Programming Manual) it will emit a Beep tone to signify that it has successfully been programmed.
3. When a Bar Code has successfully decoded the unit will emit a double beep tone.
4. Any other beep tones should not be heard. Contact support for assistance.

## Technical

For downloading the program guide or to contact us, please visit our website at [www.e-seekinc.com](http://www.e-seekinc.com).

## **Product Reference Guide**

### **Regulatory Information Radio Frequency Interference Requirements**

The Model 200 and Model 250 have been tested and found to comply with the limits for a Class B digital device pursuant to Part 15 of the FCC Rules and Regulations. These limits are designed to provide reasonable protection against harmful interference when the equipment operated in a commercial environment. This equipment generates, uses, and can radiate radio frequency energy, and if not installed and used in accordance with the instruction manual, may cause harmful interference to radio communications.

These devices comply with FCC Part 15. Operation is subject to the following two conditions: (1) these devices may not cause harmful interference and (2) these devices must accept any interference received, including interference that may cause undesired operation.

### **Radio Frequency Interference Requirements – Canada**

The Model 200 and Model 250 comply with RSS 210 of Industry & Science Canada. These Class B digital devices comply with Canadian ICES-003.

### **CE Marking and European Union Compliance**

Products intended for sale within the European Union are marked with the CE Mark which indicates compliance to applicable Directives and European Normes (EN). The Model 200 and Model 250 have been tested and are certified to meet all applicable Directives and European Normes.

### Appendix A

Mounting picture.

Model 250

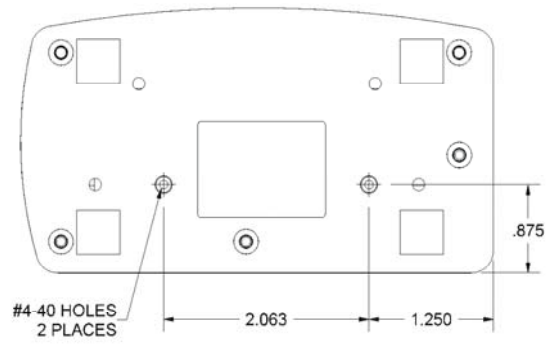

Model 200

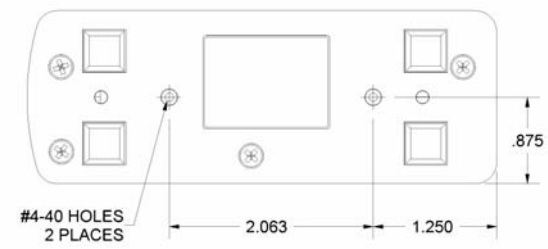

## Appendix B

### Model 200/250 Serial Port Pin outs (RJ-45)

Pin Number	Description
1	Reserved
2	VCC (7 - 20 VDC)
3	Reserved
4	Reserved
5	Ground
6	TxD (Transmit Data)
7	RxD (Receive Data)
8	RTS (Request To Send)
9	CTS (Clear To Send)
10	+5 VDC **

\*\* Only available on M200-5 model

**Notes**



200900-A0